

HKEX GUIDANCE LETTER

HKEX-GL78-14 (Published in May 2014) (Updated in February 2018)

(Withdrawn and replaced by HKEX-GL104-19 – October 2019)

Subject	Guidance on application of the reverse takeover requirements under Rule 14.06(6) (GEM Rule 19.06(6))
Listing Rules	Main Board Rules 14.06(6), 14.54, 14.55, 14.57, 14.92 and 14.93 GEM Rules 19.06(6), 19.54, 19.55, 19.57, 19.91 and 19.92
Related publications	Listing Decisions HKEX-LD75-1, LD75-2, LD95-1, LD95-2, LD95-3, LD95-4, LD95-5, LD7-2011, LD29-2012, LD39-2013, LD41-2013, LD43-2013, LD44-2013, LD57-2013, LD58-2013, LD-59-2013

Important note: *This letter does not override the Listing Rules and is not a substitute for advice from qualified professional advisers. If there is any conflict or inconsistency between this letter and the Listing Rules, the Listing Rules prevail. You may consult the Listing Department on a confidential basis for an interpretation of the Listing Rules, or this letter.*

A. Purpose

1. This guidance letter reflects the Exchange's current practice in application of the reverse takeover (RTO) requirements under Rule 14.06(6) (GEM Rule 19.06(6)) and related administrative requirements.

B. Relevant Rules

Definition

2. Rule 14.06(6) (GEM Rule 19.06(6)) defines a RTO to be an acquisition (or series of acquisitions) which constitute, in the opinion of the Exchange, an attempt to achieve a listing of the assets to be acquired and a means to circumvent the requirements for new applicants. This is a **principle based test**.
3. Rules 14.06(6)(a) and (b) (GEM Rule 19.06(6)(a) and (b)) also set out two specific forms of RTO, and refers to: (a) an acquisition (or series of acquisitions) which constitute a very substantial acquisition where there is or which will result in a change in control of the issuer (as defined in the Takeovers Code); or (b) an acquisition (or acquisitions) from the incoming shareholder or his associate(s) within 24 months of the incoming shareholder gaining control, which individually or together constitute a very substantial acquisition. These are the **bright line tests** and refer to specific forms of reverse takeovers¹ involving a change of control of the issuer.

¹ Reverse takeovers may also include transactions involving the injection of assets into an issuer to achieve a listing of assets which do not involve a change of control of the issuer.

Compliance with new listing requirements

4. Where a transaction is treated as a RTO, the issuer will be treated as if it were a new listing applicant under Rule 14.54 (GEM Rule 19.54). The enlarged group or the assets to be acquired must meet the track record requirements for new applicants under Rule 8.05 (GEM Rule 11.12A), and the enlarged group must meet all other new listing requirements under Chapter 8 of the Rules (Chapter 11 of the GEM Rules). Rule 14.55 (GEM Rule 19.55) requires the RTO transaction to be approved by shareholders². Rule 14.57 (GEM Rule 19.57) requires the issuer to comply with the procedures and requirements for new listing applications set out in Chapter 9 of the Rules (Chapter 12 of the GEM Rules), and to issue a listing document.

Disposal restrictions

5. Rules 14.92 and 14.93 (GEM Rules 19.91 and 19.92) state that an issuer may not dispose of its existing business within 24 months after a change in control, unless the asset injection(s) from the new controlling shareholder and his associates and any assets acquired during the period leading to and after the change in control would meet the trading record requirement under Rule 8.05 (GEM Rule 11.12A). The Rules discourage circumvention of the bright line tests by deferring a disposal such that the assets acquired would not result in a very substantial acquisition.

C. Listing Committee guidance on the application of the RTO Rules

6. The Listing Committee considered the RTO Rules and their application in November 2009, August 2010 and October 2013³. It noted that the RTO Rules are anti-avoidance provisions designed to prevent circumvention of the new listing requirements. As such, they involve an application of judgment. Taken to the extreme, any material acquisition could be viewed as an attempt to achieve a listing of the assets to be acquired. A balance needs to be struck between allowing legitimate business activities (such as business combinations and expansions) and the need to maintain market quality (by subjecting these transactions to the new listing requirements).
7. If a transaction falls outside the bright line tests, the Exchange will apply the principle based test to assess whether the acquisition constitutes an attempt to achieve a listing of the assets to be acquired and a means to circumvent the requirements for new listing. The transaction would be treated as a RTO under the principle based test if the Exchange considers it is an “extreme” case taking into account the following criteria:
 - the size of transaction relative to the size of the issuer;
 - the quality of the business to be acquired – whether it can meet the trading record requirements for listings, or whether it is unsuitable for listing (e.g. an early stage exploration company);

² Under the Rule, where there is a change in control under Rule 14.06(6) (GEM Rule 19.06(6)), any outgoing shareholder, incoming shareholder and their associates may not vote in favour of the proposal to inject assets by the incoming shareholder.

³ See the 2009, 2010 and 2013 Listing Committee Annual Reports published on the HKEx website at www.hkex.com.hk

- the nature and scale of the issuer’s business before the acquisition (e.g. whether it is a listed shell);
 - any fundamental change in the issuer’s principal business (e.g. the existing business would be discontinued or very immaterial to the enlarged group’s operations after the acquisition);
 - other events and transactions (historical, proposed or intended) which, together with the acquisition, form a series of arrangements to circumvent the RTO Rules (e.g. a disposal of the issuer’s original business simultaneously with a very substantial acquisition); and
 - any issue of **Restricted Convertible Securities**⁴ to the vendor which would provide it with de facto control of the issuer.
8. A transaction would be treated as an extreme very substantial acquisition (**extreme VSA**)⁵ where the Exchange considers it “extreme” by reference to the criteria set out in paragraph 7, but the assets to be acquired can meet the minimum profit requirement under Rule 8.05 (the positive cash flow requirement under GEM Rule 11.12A) and circumvention of new listing requirements would not be a material concern. Extreme VSAs are presented to the Listing Committee for its decision.
9. Where the Committee resolves that the RTO Rules will apply, the issuer will be treated as if it were a new listing applicant and will be subject to all applicable listing requirements for new applicants (see paragraph 4). Where the Committee resolves that the RTO Rules will not apply to an extreme VSA, the issuer will be required to prepare a transaction circular under an enhanced disclosure and vetting approach⁶, and to appoint a financial adviser to conduct due diligence on the acquisition⁷. The responsibilities of, and the scope of work to be performed by the financial adviser, are set out in the Attachments.
10. Where a very substantial acquisition is not considered to be extreme, the issuer may nevertheless be required to prepare a transaction circular under an enhanced disclosure and vetting approach. This serves to provide shareholders with information about the transaction and the intentions of the company.

⁴ **Restricted Convertible Securities** are highly dilutive convertible securities with a conversion restriction mechanism (e.g. restriction from conversion that would cause the securities holder to hold 30% interest or higher) avoid triggering a change of control under the Code on Takeovers and Mergers.

⁵ The term “extreme VSA” is interchangeable with the term “borderline case” used in the discussions about reverse takeovers in the 2009, 2010 and 2013 Listing Committee Annual Reports.

⁶ See paragraph 30 of this letter.

⁷ Where the acquisition involves natural resources and competent person report and valuation report are prepared under Chapter 18 of the Rules (Chapter 18A of the GEM Rules), the Listing Committee may not apply additional due diligence requirements.

11. The flowchart below illustrates the RTO assessment and requirements:

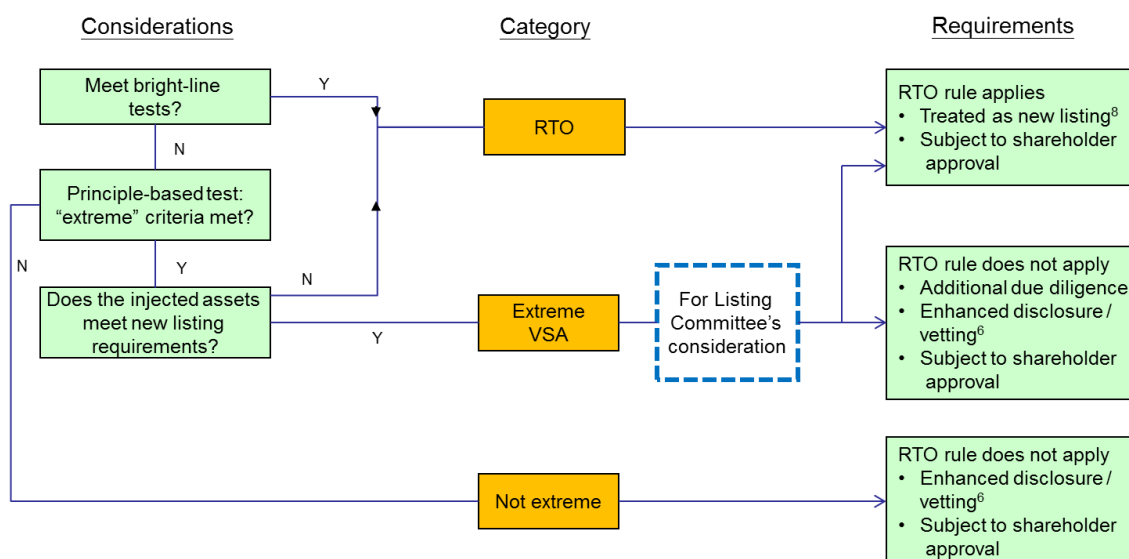

D. Further Guidance of the criteria under the principle based test

12. In assessing the principle based test, the Exchange will consider all the criteria set out in paragraph 7 and whether, taken together, the proposed acquisition would be considered a proposal to circumvent the new listing requirements and a means to achieve the listing of the assets.
13. While an assessment is made based on a combination of the criteria, the Exchange has the following observations based on precedent cases:

Fundamental change in the issuer's principal business

14. Where an issuer acquires a business that is completely different from its existing business, it is more likely to be viewed as a means to achieve the listing of the target assets. This is more so the case where the target business is specialized and the present management has no expertise; or where the issuer's existing business is so immaterial that post-acquisition, the issuer would be substantially carrying on only the new business.
15. The Exchange normally does not consider acquisitions of assets for expansion or development of existing businesses as "extreme".

Nature and scale of the issuer's business before the acquisition

16. If an issuer carries on minimal operations (e.g. shell companies), a material asset injection is more likely to be considered an "extreme" case as the target assets would be listed after the acquisition. An example is a PN17 company⁹ (see LD75-1).

⁸ The transaction may not proceed if the injected assets cannot meet the new listing requirements.

⁹ A PN17 company is a company that is suspended and in the delisting stages under Practice Note 17 to the Rules (GEM Rule 9.15).

17. The Exchange will consider the nature of the issuer's existing business and its financial position. For example, if an issuer operates a trading business that has a low level of activities and generates minimal gross profit and losses (which does not appear to be sustainable and viable), or operates a business of "treasury management" of its substantial positions in cash and short term investments, it is more likely to be considered a shell company.

Quality of the target asset or business

18. In general, an acquisition of a target business that is not suitable for listing will likely be considered a circumvention of the new listing requirements (e.g. early exploration companies, or a business that operates illegally).
19. In the Exchange's experience, enhanced disclosure is less meaningful for acquisitions of new business or assets that have no track record or have yet to commence operations. This is more so the case where the target's business is completely different from that of the issuer (see LD95-4). They would more likely be treated as new listings. Examples include an acquisition of a patent for new technology or new business proposals where the infrastructure (e.g. production facilities) is under construction.

Size of transaction relative to the issuer

20. Where an issuer undertakes an acquisition of significant size, its existing principal business may become immaterial after the transaction, supporting a concern that the transaction may represent a means to achieve a listing of the target business.
21. The Exchange does not prescribe an absolute threshold in determining whether the size of transaction is extreme. In determining the impact of the acquisition on the issuer, the Exchange would take into account other criteria such as the nature and scale of issuer's existing business after the acquisition, and whether the acquisition would result in a fundamental change in the issuer's business.

Events and transactions which together with the acquisition form a series of arrangement to circumvent the RTO Rules

22. Proposals involving an asset swap, or disposal of the existing business to the exiting shareholder may be indications that the issuer is "cleaning" its "shell" to achieve a listing of the target business (see LD95-2).
23. Where an issuer acquires equity interests in a target in stages, the Exchange may aggregate the acquisitions in considering whether the acquisitions together are material to the issuer and represent an intention to achieve listing of the target.

Change in de facto control arising from issue of Restricted Convertible Securities

24. The Exchange notes some proposals involve the issue of Restricted Convertible Securities as consideration for proposed acquisitions. In some cases issuers failed to demonstrate the business rationale for the structure, which raised questions whether it is a means to avoid a change in control under the bright line tests.

25. Where a proposal does not fall under the bright line test, it may nevertheless be treated as a RTO under the principle based test. In circumstances involving the issue of Restricted Convertible Securities, the Exchange would consider whether in substance, the structure serves to allow the vendor (who will hold the issuer's convertible securities) to effectively "control" the issuer. For example, the vendor would become a controlling shareholder of the issuer assuming the convertible securities were fully converted and where i) the issuer has no controlling shareholder when it proposes the acquisition; or ii) the existing controlling shareholder would cease to be a controlling shareholder after the conversion.
26. The Exchange would consider any change in de facto control in conjunction with the other criteria (which assess whether there is a listing of the target assets and a means to circumvent the new listing requirements) in assessing whether to treat a transaction as a RTO.

E. Documentary requirements for very substantial acquisition or reverse takeover

27. Under Rule 13.52(2)(a) (GEM Rule 17.53(2)(a)), an announcement of a very substantial acquisition or a reverse takeover is subject to pre-vetting by the Exchange.
28. An issuer may be required to suspend trading in its shares pending the release of acquisition announcement. In the interests of promoting a continuous market for the trading of listed securities, the suspension period should be kept as short as possible. Furthermore, a suspension does not relieve an issuer of its obligations under Part XIVA of the Securities and Futures Ordinance to announce inside information¹⁰.
29. To minimize the suspension period an issuer should provide the Exchange with sufficient information to make an assessment of the RTO Rules at an early stage of pre-vetting of the announcement. The issuer should provide relevant documents and information when it first submits the acquisition announcement for pre-vetting. For example:
 - Draft financial statements / accounts of the target business over the track record period.
 - Where the consideration for acquisition is supported by a valuation, the valuation report and the underlying assumptions.
 - For an acquisition of natural resources, the competent person's report to support the amount of estimated resources and reserves, and the working capital forecast memorandum to demonstrate sufficiency of the enlarged group's working capital.
 - For an acquisition of business under contractual arrangements, a legal opinion for demonstrating that such arrangements can meet the conditions set out in our Guidance Letter HKEx-GL77-14.

¹⁰ See Paragraph 44 of "Guidelines on Disclosure of Inside Information (June 2012)" published by the Securities and Futures Commission.

F. Disclosure in circulars

30. Where a transaction is treated as a RTO, the issuer is required to issue a circular that complies with the new listing requirements. A very substantial acquisition that is not treated as a RTO may nevertheless amount to a material change to the issuer's business, management and/or mode of operations. In such circumstances, to ensure shareholders and investors are provided with material information about the target and the future business prospects of the issuer, it should enhance disclosure in the circular, applying the standard of disclosure for listing documents for new listing applicants.
31. The Exchange highlights the areas below for issuers' attention.

Issuer's business plans and future prospects

32. To ensure shareholders are given a full picture of the issuer's directions and the intentions of its directors, the Exchange will make enquiries of, and issuers should disclose their intention to make significant changes in i) the enlarged group's business and/or arrangements for potential acquisitions or disposals of assets; ii) the issuer's board composition; and iii) the management of the target business.
33. This information should be disclosed in the circular to assist the shareholders in making a reasonable assessment about the prospects and development of the enlarged group.

Disclosure of impairment assessment

34. Under Hong Kong Accounting Standards 36 – Impairment of Assets, an issuer is required to conduct an impairment assessment of the target for the purpose of preparing pro forma financial statements in the circular, adopting a valuation methodology that is consistent with the accounting standards and the issuer's accounting policy.
35. Issuers should make appropriate pro forma adjustments taking into account any impairment of assets, based on the valuation reports and in accordance with the accounting standards for impairment. The auditors should provide reasonable assurance on the pro forma accounts applying the Hong Kong Standard on Assurance Engagements 3420 "Assurance Engagements to Report on the Compilation of Pro Forma Financial Information Included in a Prospectus". Where there are material impairments, issuers should also disclose the results of such impairment assessment in the circulars, together with information about the valuation including the methodology adopted and major assumptions.

G. Disclosure in annual reports

36. Under Paragraph 32 of Appendix 16 (GEM Rule 18.41), an issuer should include in its annual report a discussion and analysis of the acquired business' performance and the material factors underlying its results and financial position, including a discussion on trends and significant events during the financial year.

37. Where there is any material change to the acquired business' financial position and prospects which deviated from the disclosure in the issuer's circular, there should be a discussion on these matters. Further guidance is set out in our reports on "Review of Disclosure in Issuers' Annual Reports to Monitor Rule Compliance".

ATTACHMENT 1

Where an issuer proposing an extreme VSA is required to appoint a financial adviser to conduct due diligence on the transaction, it and its financial adviser should observe the following:

1. The financial adviser should be a person licensed or registered under the Securities and Futures Ordinance for Type 6 regulated activity and permitted under its license or certificate of registration to undertake the work as a sponsor. The transaction team appointed by the financial adviser to carry out the due diligence work should comprise staff with appropriate levels of knowledge, skills and experience and include a Principal¹ who acts as the supervisor of the team.
2. The financial adviser is required to provide a declaration to the Exchange in respect of its due diligence on the transaction in the form set out in Attachment 2.
3. The extent of the financial adviser's work and scope of due diligence should be referenced to Practice Note 21 to the Rules (Practice Note 2 to the GEM Rules). In undertaking that due diligence, the financial adviser is expected to refer to the procedures sponsors would typically perform. That said, as every transaction is unique and so will be the due diligence that may be appropriate in any particular case, the scope and extent of appropriate due diligence may be different from the more typical examples in the Practice Note. The financial adviser must exercise its judgment as to what investigations or steps are appropriate for a particular transaction and the extent of each step.
4. The issuer should note that the financial adviser's due diligence work on the transaction would not relieve the issuer's directors of their responsibilities and obligations under the Rules. The directors remain responsible for compliance with the Rules in respect of the transaction.
5. The issuer and its directors should assist the financial adviser to perform its duties:
 - (a) The issuer should afford the financial adviser full access at all times to all persons, premises and documents relevant to the financial adviser's performance of its duties. In particular, the terms of engagement with experts retained to perform services related to the transaction should contain clauses entitling the financial adviser access to (i) any such expert; (ii) the expert's reports, draft reports (both written and oral), and terms of engagement; (iii) information provided to or relied on by the expert; (iv) information provided by the expert to the Exchange or the Securities and Futures Commission (the Commission); and (v) all other correspondence exchanged between the issuer or its agents and the expert or between the expert, the issuer and the Exchange or Commission.
 - (b) The issuer should keep the financial adviser informed of any material change to any information previously given to or accessed by the financial adviser under paragraph (a) above.
 - (c) The issuer should provide to or procure for the financial adviser all necessary consents to the provision of the information referred to in paragraphs (a) and (b) above to the financial adviser.

¹ As defined in Paragraph 17 of the Code of Conduct for Persons Licensed by or Registered with the Securities and Futures Commission.

ATTACHMENT 2

[letterhead of financial adviser]

Financial adviser's declaration

To: The Listing Department
The Stock Exchange of Hong Kong Limited

...../...../.....

We,, are the financial adviser appointed by (the "Company") on [Date] to perform due diligence on [a description of the proposed transaction] (the "Transaction") as required by The Stock Exchange of Hong Kong Limited (the "Exchange") for the purpose of the [Rules Governing the Listing of Securities on The Stock Exchange of Hong Kong Limited (the "Exchange Listing Rules") / Rules Governing the Listing of Securities on GEM of The Stock Exchange of Hong Kong Limited (the "GEM Listing Rules")] and have offices located at

We declare to the Exchange that:

- (a) having made reasonable due diligence inquiries, we have reasonable grounds to believe and do believe that:
 - (i) the assets to be acquired under the Transaction is able to meet [the minimum profit requirements under Exchange Listing Rule 8.05 / the positive cash flow requirement under GEM Listing Rule 11.12A] and the enlarged group is able to meet all the other conditions in [Chapter 8 of the Exchange Listing Rules / Chapter 11 of the GEM Listing Rules] (except for those rules agreed with the Exchange);
 - (ii) the Company's circular contains sufficient particulars and information to enable a reasonable person to form as a result thereof a valid and justifiable opinion of the Transaction, the financial condition and profitability of the assets to be acquired under the Transaction at the time of the issue of the circular;
 - (iii) the information in the non-expert sections of the circular:
 - (A) contains all information required by relevant legislation and rules;
 - (B) is true, accurate and complete in all material respects and not misleading or deceptive in any material respect, or, to the extent it consists of opinions or forward looking statements by the Company's directors or any other person, such opinions or forward looking statements have been made after due and careful consideration and on bases and assumptions that are fair and reasonable; and
 - (C) does not omit any matters or facts the omission of which would make any information in the non-expert sections of a circular or any other part of the circular misleading in a material respect; and
 - (iv) there are no other material issues relating to the Transaction which, in our opinion, should be disclosed to the Exchange;

ATTACHMENT 2

- (b) in relation to each expert section in the circular, having made reasonable due diligence inquiries, we have reasonable grounds to believe and do believe (to the standard reasonably expected of a financial adviser which is not itself expert in the matters dealt with in the relevant expert section) that:
 - (i) where the expert does not conduct its own verification of any material factual information on which the expert is relying for the purposes of any part of the expert section, such factual information is true in all material respects and does not omit any material information. Factual information includes:
 - (A) factual information that the expert states it is relying on;
 - (B) factual information we believe the expert is relying on; and
 - (C) any supporting or supplementary information given by the expert or the Company to the Exchange relating to an expert section;
 - (ii) all material bases and assumptions on which the expert sections of the circular are founded are fair, reasonable and complete;
 - (iii) the expert is appropriately qualified, experienced and sufficiently resourced to give the relevant opinion;
 - (iv) the expert’s scope of work is appropriate to the opinion given and the opinion required to be given in the circumstances (where the scope of work is not set by a relevant professional body);
 - (v) the expert is independent from (1) the Company and its directors and controlling shareholder(s); (2) the counterparty to the Transaction and the assets to be acquired; and (3) the directors and controlling shareholder(s) of the counterparty to the Transaction; and
 - (vi) the circular fairly represents the views of the expert and contains a fair copy of or extract from the expert’s report; and
- (c) in relation to the information in the expert reports, we, as a non-expert, after performing reasonable due diligence inquiries, have no reasonable grounds to believe and do not believe that the information in the expert reports is untrue, misleading or contains any material omissions.

Signed:
Name:
For and on behalf of: *[insert the name of financial adviser]*
Dated:

ATTACHMENT 2

Note: Each and every director of the financial adviser, and any officer or representative of the financial adviser supplying information sought in this form, should note that this form constitutes a record or document which is to be provided to the Exchange in connection with the performance of its functions under “relevant provisions” (as defined in Part 1 of Schedule 1 to the Securities and Futures Ordinance (Cap 571) as amended from time to time) and is likely to be relied upon by the Exchange. Therefore, you should be aware that giving to the Exchange any record or document which is false or misleading in a material particular will render relevant persons liable for prosecution for an offence under subsection 384(3) of the Securities and Futures Ordinance (Cap 571) as amended from time to time. If you have any queries you should consult the Exchange or your professional adviser immediately.